

NOTES: 1-MUST BE FREE OF BURRS, SHARP CORNERS - EDGES
BREAK = 0.015 R. OR 0.015 X 45° CHAMFER.

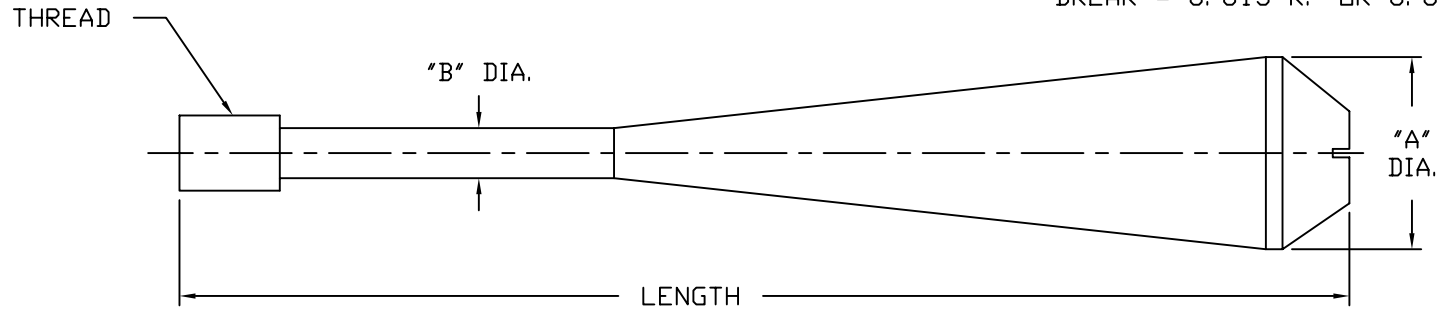

COUPLING SIZE	DRAWBAR	LENGTH	"A" DIA.	"B" DIA.	THREAD
1"	16127	7.50	.859	.320	9/16 - 18
1-1/2"	16110	8.38	1.375	.500	" "
1-1/2" CAMLOCK	16110	8.38	1.375	.500	" "
1-1/2" RACK	16110	8.38	1.375	.500	" "
1-1/2" STORZ	16110	8.38	1.375	.500	" "
1-3/4"	16107	8.75	1.437	.375	" "
1-3/4" STORZ	16107	8.75	1.437	.375	" "
2" X 1-1/2"	16107	8.75	1.437	.375	" "
2"	16135	8.81	1.688	.750	" "
2" CAMLOCK	RH16178	10.00	1.437	.460	" "
2-1/2"	16102	10.56	2.000	1.000	7/8 - 16
2-1/2" CAMLOCK	16124	10.25	2.125	.625	" "
2-1/2" RACK	16124	10.25	2.125	.625	" "
3" X 2-1/2"	16124	10.25	2.125	.625	" "
3"	16102	10.56	2.000	1.000	" "

DRAWBARS NOT SHOWN:

1-1/2" BIT #16195

2-1/2" BIT #16203

CONTACT FACTORY FOR THESE
DRAWBARS

TITLE		DIMENSIONS - DRAWBARS 1" TO 3" COUPLINGS	
UNLESS OTHERWISE SPECIFIED TOLERANCES TO BE:		RED HEAD BRASS LLC SHREVE, OH.	
DECIMAL	FRACTIONS	SCALE	DRAWN DATE
X.XXX ± 0.005	± 1/64	FULL	J. CARROLL
X.XX ± 0.01		& AS NOTED	01/04/06
DRAWING UNITS = INCHES		APP'D DATE	
ANGLES = ± 1/2°		DRAWBARS 1	
125 ON ALL MACHINE SURFACES		REV.	
DO NOT SCALE DRAWING			

REV	DESCRIPTION OF REVISION	CHG'D BY	DATE
STYLE	MAT'L	FINISH	PER ORDER
	STEEL		

THIS DRAWING IS THE PROPERTY OF RED HEAD BRASS LLC, AND THE CONTENTS HEREIN ARE PROPRIETARY AND CONFIDENTIAL. THE CONTENTS OF THIS DRAWING MAY NOT BE DISCLOSED OR USED BY ANYONE WITHOUT PRIOR WRITTEN CONSENT OF THE MANAGEMENT OF RED HEAD BRASS LLC. IT MAY NOT BE USED FOR MANUFACTURING UNLESS FULLY SIGNED.

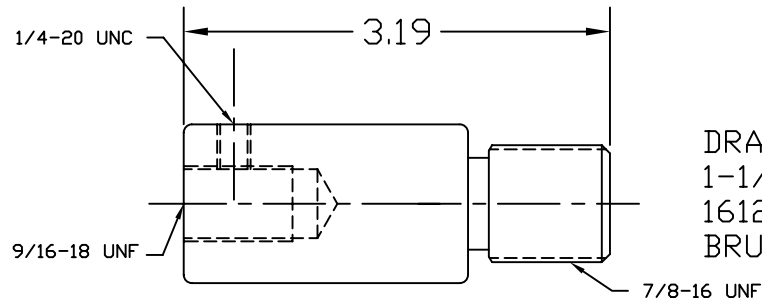

NOTES: 1-MUST BE FREE OF BURRS, SHARP CORNERS - EDGES
BREAK = 0.015 R. OR 0.015 X 45° CHAMFER.

DRAWBAR ADAPTER
1-1/2", 1-3/4", 2" CAMLOCK, 2"X1-1/2"
16120-10007
BRUTE I, II, & X-PANDER

THREAD NOTE:
DRAWBAR END - 9/16-18.
2" DRAWBAR ONLY - 3/4-10
CYLINDER END - 7/8-16

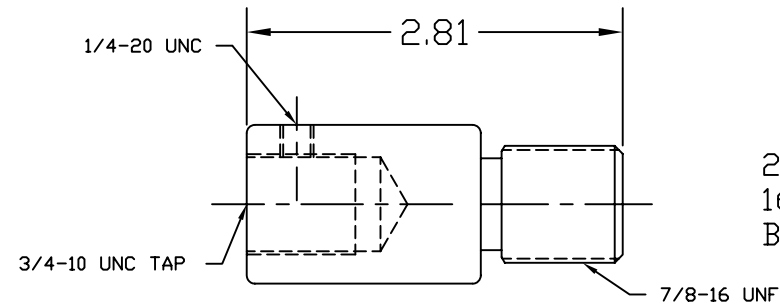

2" DRAWBAR ADAPTER
16137-10074
BRUTE I, II, & X-PANDER

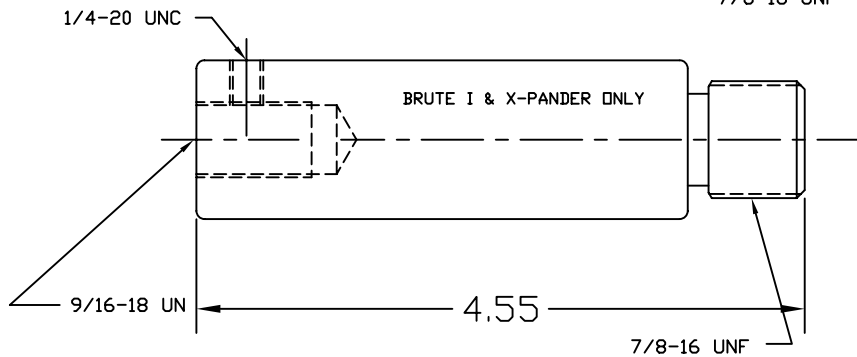

1" DRAWBAR ADAPTER
16157-1-10278
BRUTE I & X-PANDER
ONLY

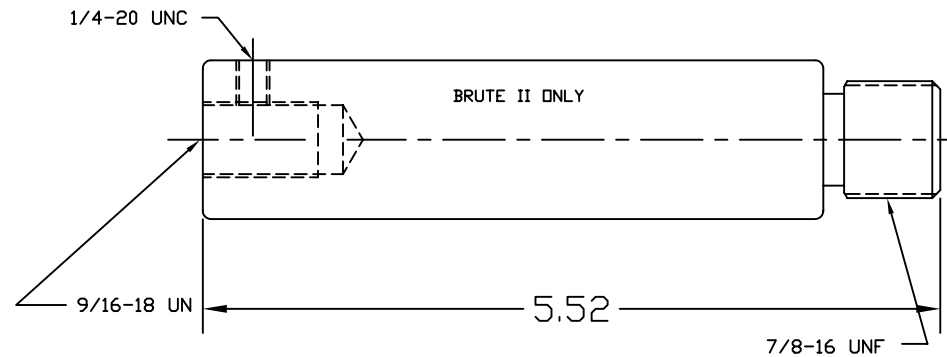

1" DRAWBAR ADAPTER
16157-2-10227
BRUTE II

REV	DESCRIPTION OF REVISION	CHG'D BY	DATE
STYLE	MAT'L	FINISH	
	STEEL		

THIS DRAWING IS THE PROPERTY OF RED HEAD BRASS LLC, AND THE CONTENTS HEREIN ARE PROPRIETARY AND CONFIDENTIAL. THE CONTENTS OF THIS DRAWING MAY NOT BE DISCLOSED OR USED BY ANYONE WITHOUT PRIOR WRITTEN CONSENT OF THE MANAGEMENT OF RED HEAD BRASS LLC. IT MAY NOT BE USED FOR MANUFACTURING UNLESS FULLY SIGNED.

TITLE		DRAWBAR ADAPTERS	
UNLESS OTHERWISE SPECIFIED TOLERANCES TO BE:			
DECIMAL	FRACTIONS		
X.XXX ± 0.005	± 1/64		
X.XX ± 0.01			
DRAWING UNITS = INCHES			
ANGLES = ± 1/2°			
125 ON ALL MACHINE SURFACES			
DO NOT SCALE DRAWING			
		RED HEAD BRASS LLC	
		SHREVE, OH.	
SCALE	DRAWN	DATE	APP'D
FULL	J. CARROLL		
& AS NOTED			
DRAWBAR ADAPT			REV.